



## GOAT BUILT DUAL CBR-PUMP BRACKET

Thank you for purchasing Goat Built components, before starting your installation, we recommend that you read through these instructions to familiarize yourself with the steps and parts so you can plan and prepare for your install accordingly.

A few notes about the 4404 pump bracket:

- These instructions work with either 99 to 12 GM truck Vortec 4.8/5.3/6.0 and 2010+ Camaro LS3 pulley spacing or F-body spacing. The difference is the spacers between the head and rear bracket and bolt lengths. Refer to the drawing for assembly direction.
- You will need a GM truck idler pulley, 99-10. Gates P/N 38001 or Goat Built 4462
- This bracket kit was designed to work with the Goat Built 4405-20 or 4405-10, passenger side alternator/tensioner bracket
- If you want to use an LS F-body water pump with truck belt spacing you will need 3/4" water pump spacers with the F-body water pump to get the pulley lined up.
- Another LS Car option is the 2010+ Camaro LS3 water pump, it is the same as the truck spacing, but the upper water pump outlet points forward on the driver side.
- This kit fits a CBR or TC pump, the 1/4" thick shim goes behind the CBR pump or in front of a TC pump
- A 90 degree pressure fitting is required at the top of the pump

1. Loosely install all the brackets, pump and bolts before you fully tighten any of the bolts.
2. Install the brackets to the block and head as shown in the drawing attached with the appropriate spacers. Use a M10 split lock washer under the bolt heads of the bolts that screw into the block or head.
3. Install the pumps using the 8mm bolts. Use a flat washer under the bolt heads and under the nuts.
4. Torque the 10 MM bolts to 40 ft-lbs, 8 mm bolts to 15 ft-lbs
5. Remove the stock bolt and spacer from the idler pulley. Install the idler to the 4404-01 bracket using the 4400-04 spacer, 1/2" flange bolt and flange lock nut. Torque the idler bolt to 70 ft-lbs

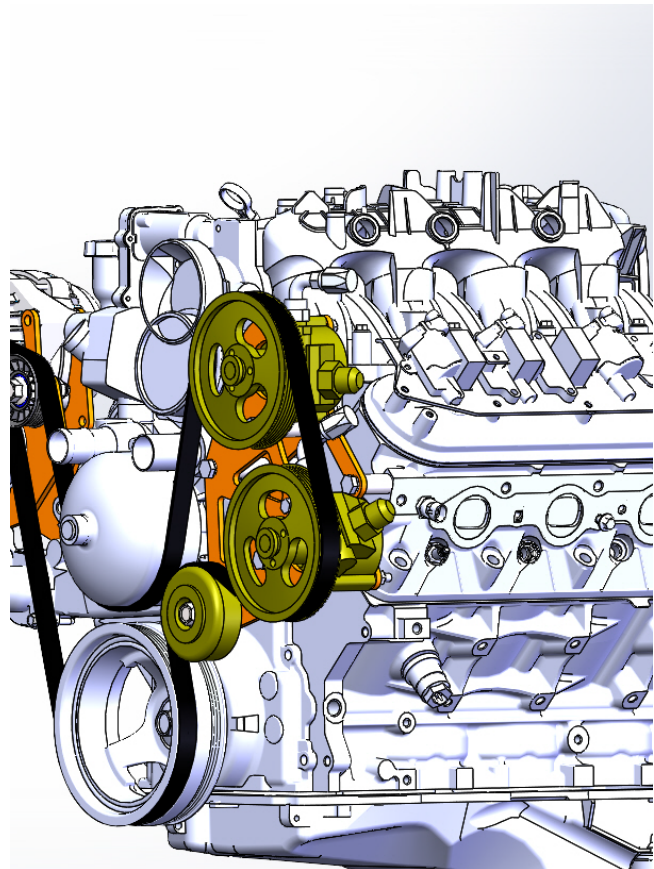

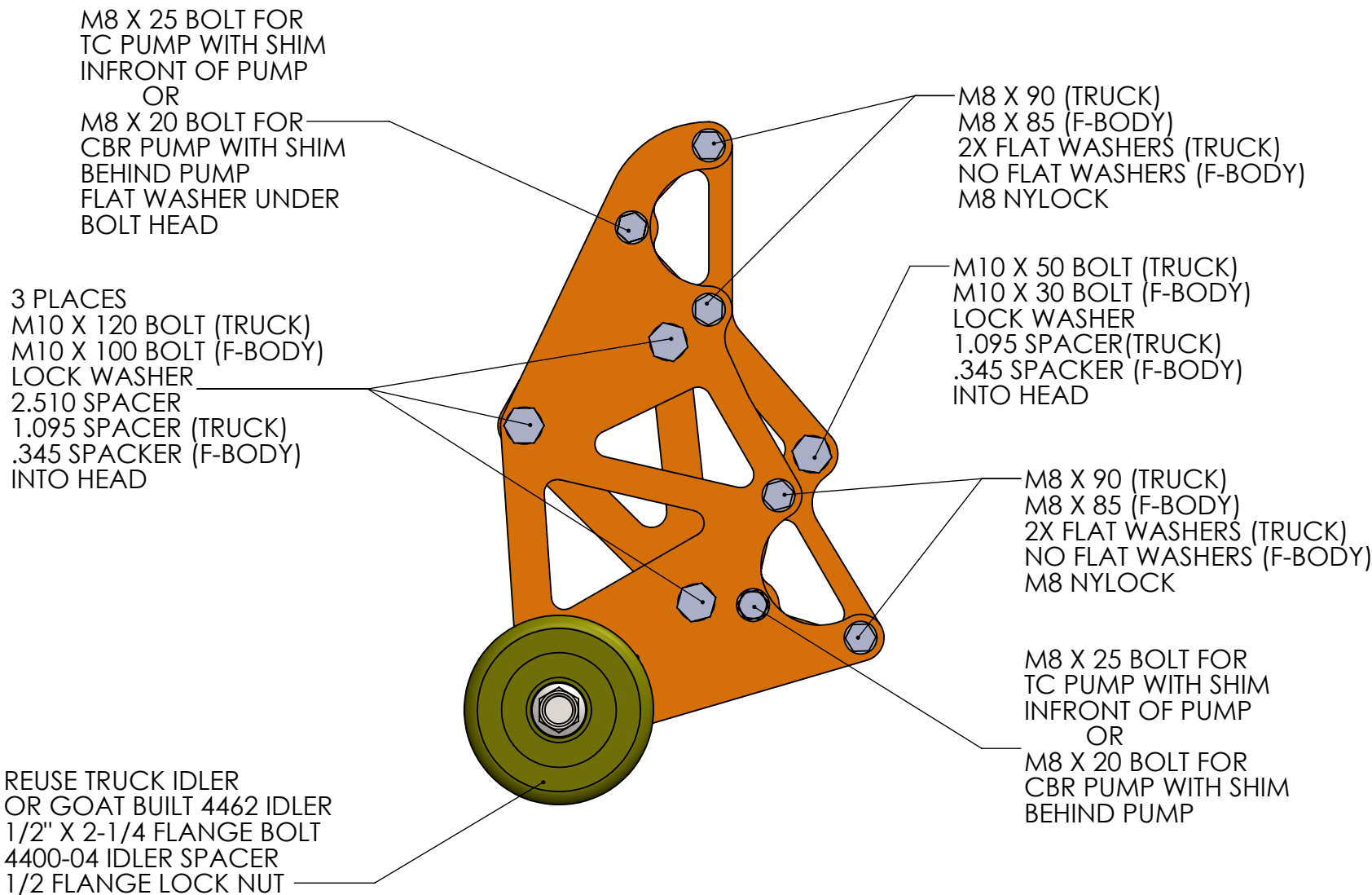

**INSTALL NOTES:**

1. THIS WILL FIT A CBR OR TC PUMP, OR ONE OF EACH, INSTALL THE PUMP SHIM ON THE FRONT OF THE PUMP FOR A TC PUMP, REAR OF THE PUMP ON A CBR
2. USE PSC PP2402, 5.5" PULLEY WITH A TC PUMP
3. USE PSC PP3608, 6" PULLEY WITH A CBR PUMP
4. THE IDLER IS NOT INCLUDED, YOU CAN RE-USE THE STOCK LS TRUCK OR USE GOAT BUILT 4462 IDLER

**GOAT BUILT**  
DESIGN & ENGINEERING · WWW.GOATBUILT.COM

TITLE: LS DUAL PUMP BRACKET  
 TRUCK/LS3 CAMARO OR F-BODY  
 SPACING, CBR OR TC PUMP

SIZE	DWG. NO.
<b>A</b>	<b>4404-T&amp;F</b>
SCALE: 1:1	WEIGHT:
SHEET 1 OF 3	

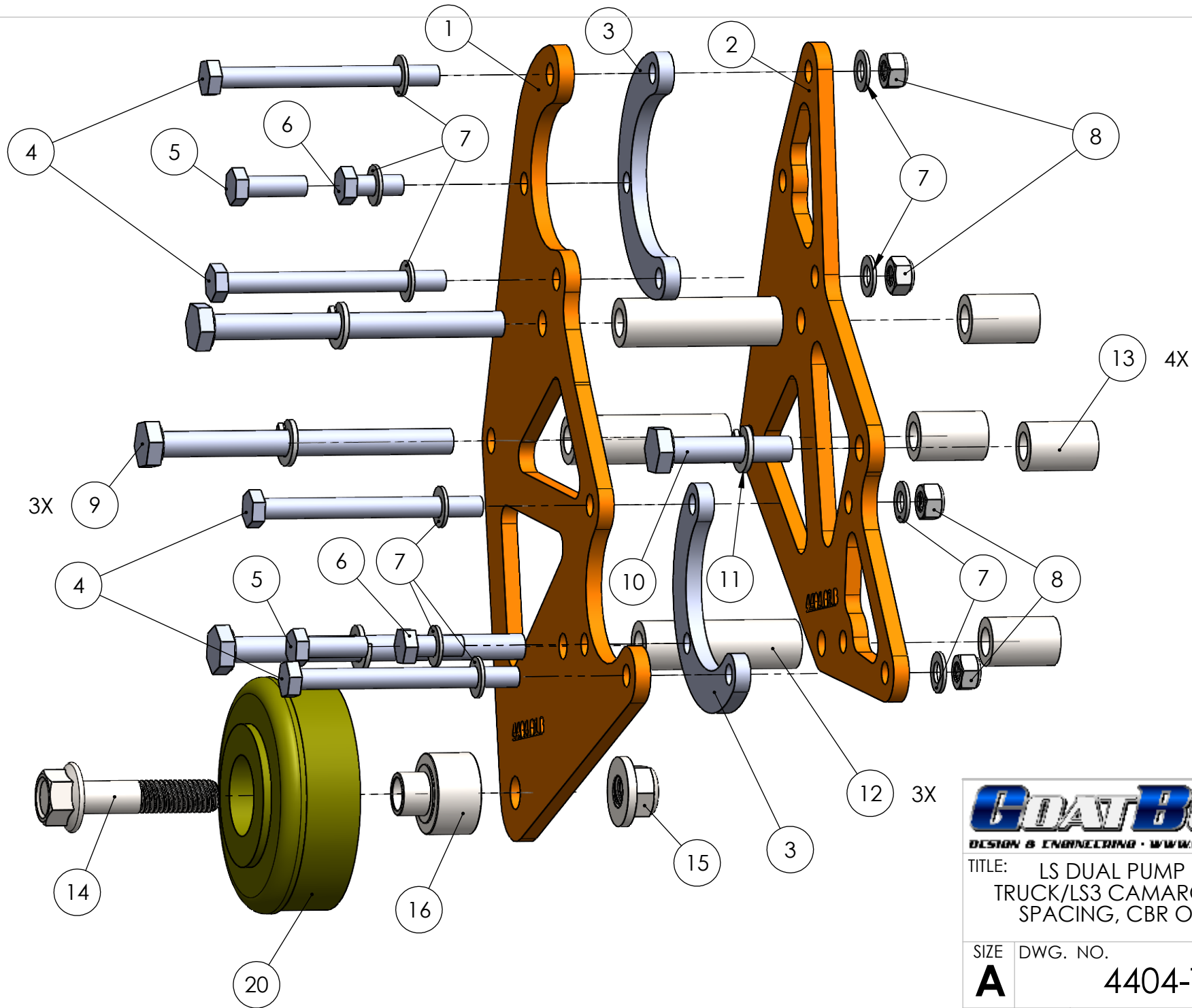

TITLE: LS DUAL PUMP BRACKET  
 TRUCK/LS3 CAMARO OR F-BODY  
 SPACING, CBR OR TC PUMP

SIZE DWG. NO.  
**A** 4404-T&F

SCALE: 1:1 WEIGHT: SHEET 2 OF 3

5

4

3

2

1

ITEM NO.	PART NUMBER	DESCRIPTION	4400-T QTY.	4400-F/ QTY.
1	4404-01	FRONT BRACKET	1	1
2	4404-02	REAR BRACKET	1	1
3	4421-04	LS ALT PS BRACKET, PUMP SHIM	2	2
4	M8X 90	M8 X 90 BOLT (TRUCK)	4	-
4	M8X 85	M8 X 85 BOLT (F-BODY)	-	4
5	M8X 25	M8 X 25 BOLT	2	2
6	M8X 20	M8 X 20 BOLT	2	2
7	M8-FW	M8-FLAT WASHER	10	6
8	M8-LN	M8 LOCK NUT	4	4
9	M10 X 120	M10 X 120 BOLT (TRUCK)	3	-
9	M10 X 100	M10 X 100 BOLT (F-BODY)	-	3
10	M10 X 50	M10 X 50 BOLT (TRUCK)	1	-
10	M10 X 30	M10 X 30 BOLT (F-BODY)	-	1
11	M10-LW	M10-LW	4	4
12	4400-2510	2.510 SPACER	3	3
13	4400-1095	1.095 SPACER (TRUCK)	4	-
13	4400-0345	.345 SPACER (F-BODY)	-	4
14	IDLER BOLT	1/2" FLANGE BOLT	1	1
15	1-2-13FLN	1/2-13 IDLER NUT	1	1
16	4400-04	IDLER SPACER	1	1
20	IDLER	STOCK TRUCK IDLER OR GOAT BUILT 4462 IDLER (NOT INCLUDED)	-	-



TITLE: LS DUAL PUMP BRACKET  
TRUCK/LS3 CAMARO OR F-BODY  
SPACING, CBR OR TC PUMP

SIZE DWG. NO.

**A**

**4404-T&F**

SCALE: 1:1

WEIGHT:

SHEET 3 OF 3